

Installation Guide

SUPERIORE

TECNO SPA

STRADA PROVINCIALE 63R 42044

GUALTIERI RE ITALY

For product information,
call 1-844-322-2111,
or visit the **SUPERIORE** Web site at
www.superiore.us

Rangehood Accessories

Congratulations

Congratulations and welcome to the world of SUPERIORE.

We hope you will enjoy and appreciate the care and attention we have put into every details of your new, state-of-the- art product.

Your SUPERIORE PRODUCT is designed to offer years of reliable service. This Use and Care Manual will provide you with the information you need to become familiar with your product's care and operation.

Your complete satisfaction is our ultimate goal. If you have any questions or comments about this product, please contact the dealer from whom you purchased it, contact our CUSTOMER CARE at 1-844-322-2111 or visit our SUPERIORE YOUTUBE CHANNEL.

We appreciate your choice of a SUPERIORE product and hope that you will again select our products.

For more information about the complete and growing selection of SUPERIORE products, contact your dealer or visit us online at WWW.SUPERIORE.US

GRAZIE !

Antonio Di Tommaso
CEO



SPLASH BACK

The splashback is used to cover the wall space between the top of the backguard or high shelf and the bottom of the hood. Place the splashback in the desired location. Secure to the wall by placing the screws that are provided in the holes on the splashback. When screws are used to fasten the panel to materials other than wood, the appropriate type anchor should be used with the screws.

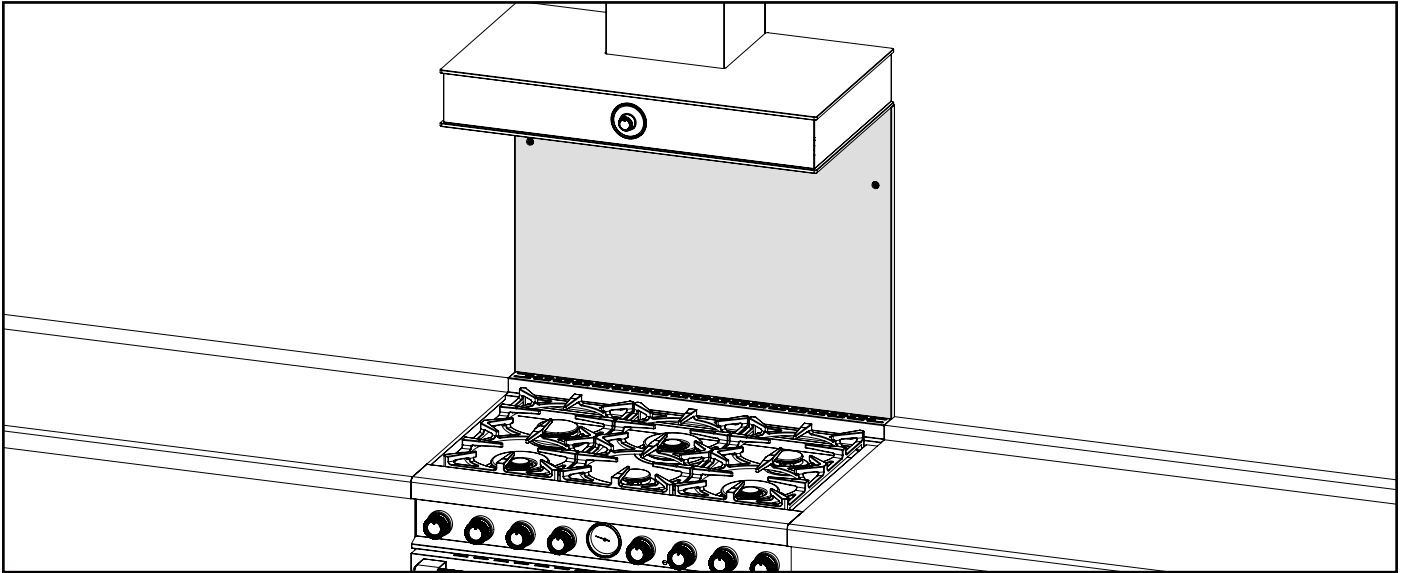

HORIZONTAL BAR INSTALLATION

If you want, you can install the bar “rail” that came with splashback. This must be done before the installation of the splashback to the wall.

Remove the closing holes and apply the horizontal bar as shown in the image below.

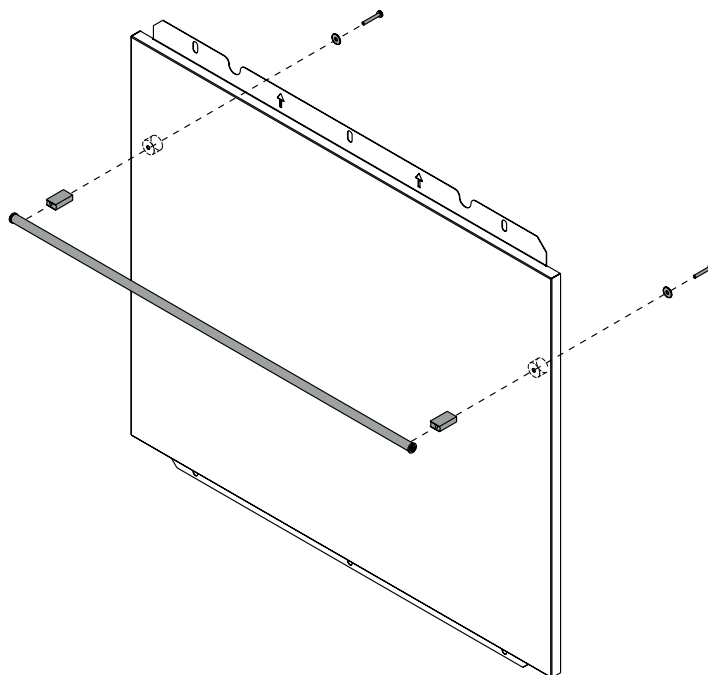

⚠ WARNING ⚠

Do not hang towels, fabrics, or any flammable material to the horizontal bar.

SPLASHBACK INSTALLATION

⚠ WARNING ⚠

Remove the stainless steel film protection before installing the splashback.

MODELS	A	B	C	D	E	F		
BSB24	24"	29" 1/2	9"	31" 17/64	-" 37/64	1" 11/64		
BSB30	30"	29" 1/2	10" 15/64	31" 17/64	-" 37/64	1" 11/64		
BSB36	36"	29" 1/2	13" 3/16	31" 17/64	-" 37/64	1" 11/64		
BSB48	48"	29" 1/2	19" 3/32	31" 17/64	-" 37/64	1" 11/64		

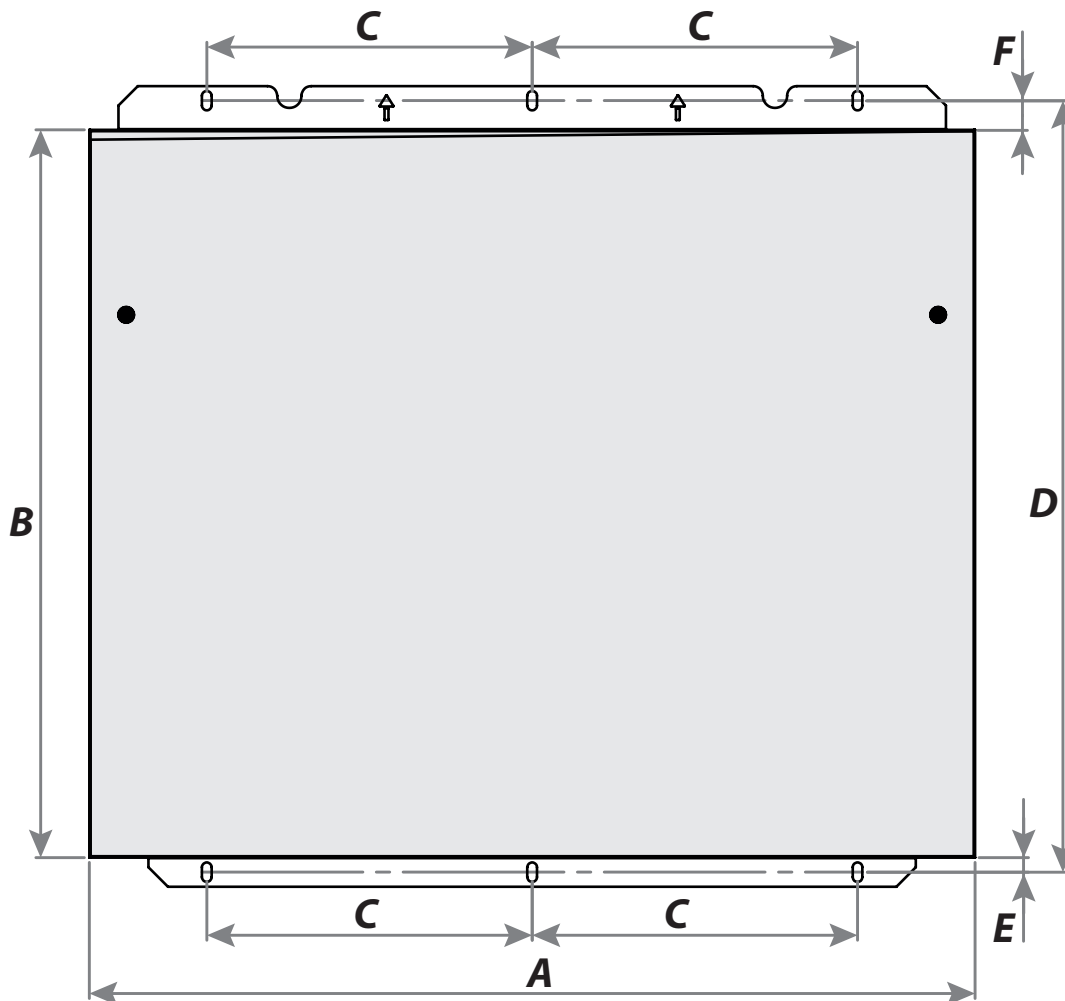

Install the splashback to the wall as shown in the image below, using the measures for the model. See table in the previous page.

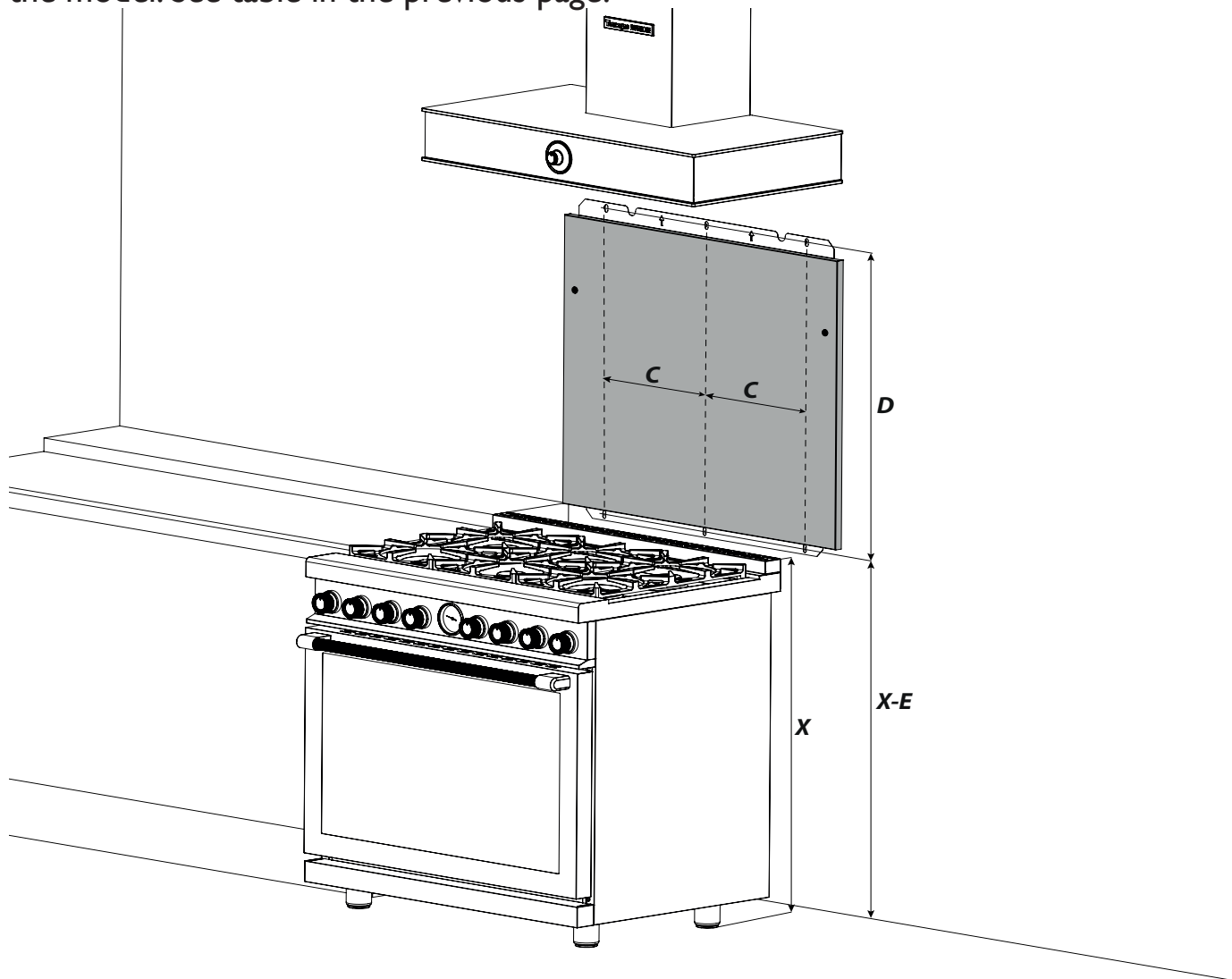

CRÉDENCE

La crédence est utilisée pour couvrir l'espace du mur entre le haut de la surface de travail ou le haut d'une étagère et le fond de la hotte. Placez la crédence à l'endroit désiré. Fixez-la au mur en plaçant les vis fournies dans les trous sur la crédence. Lorsque les vis sont utilisées pour fixer le panneau à des matériaux autres que le bois, un ancre de type approprié doit être utilisé avec les vis.

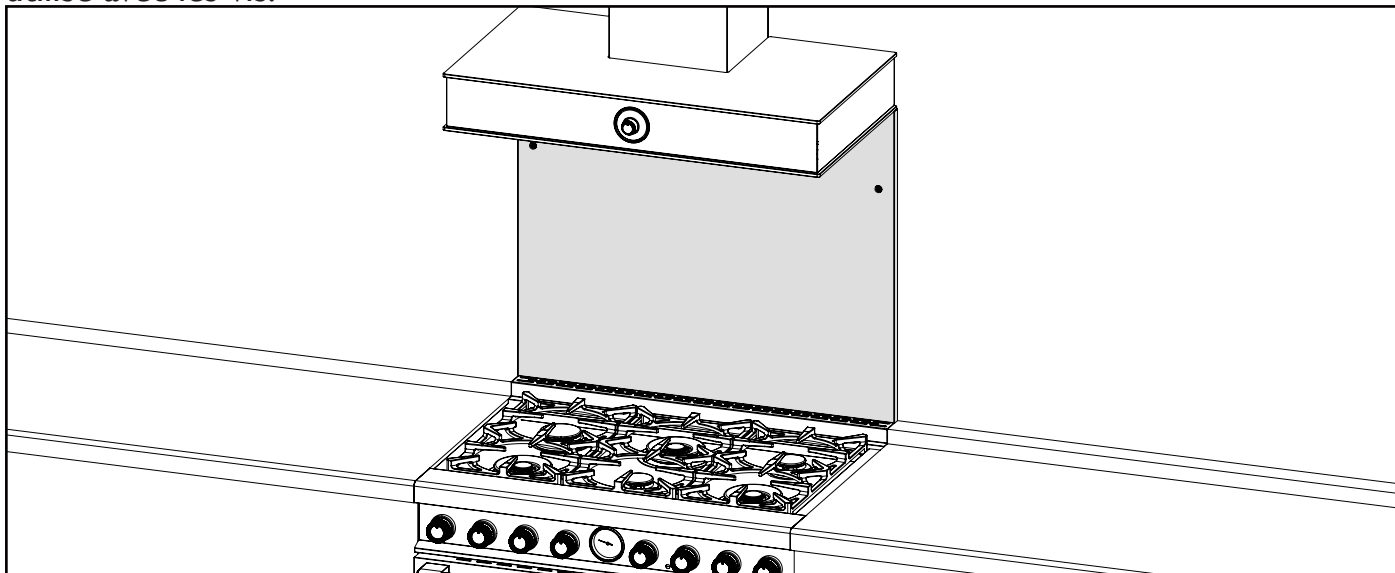

INSTALLATION DE LA PORTE ACCESSOIRE

Si vous voulez, vous pouvez installer la barre "porte accessoire" qui est vendu ensemble avec la crédence. Cela doit être fait avant l'installation de la crédence sur le mur.

Enlever les clôture des trous et appliquer la barre comme montrer dans l'image ci-dessous.

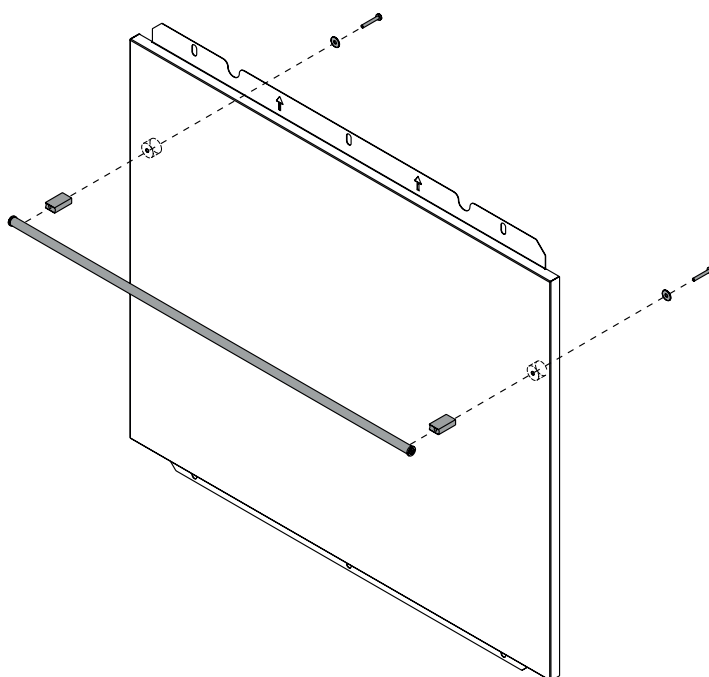

⚠ ATTENTION ⚠

Ne pas accrocher des serviettes, tissus, ou toute matière inflammable sur la barre horizontale.

INSTALLATION DE LA CRÉDENCE

⚠ ATTENTION ⚠

Enlever le film avant d'installer le dossier.

<i>MODELS</i>	<i>A</i>	<i>B</i>	<i>C</i>	<i>D</i>	<i>E</i>	<i>F</i>		
BSB24	24"	29" 1/2	9"	31" 17/64	-" 37/64	1" 11/64		
BSB30	30"	29" 1/2	10" 15/64	31" 17/64	-" 37/64	1" 11/64		
BSB36	36"	29" 1/2	13" 3/16	31" 17/64	-" 37/64	1" 11/64		
BSB48	48"	29" 1/2	19" 3/32	31" 17/64	-" 37/64	1" 11/64		

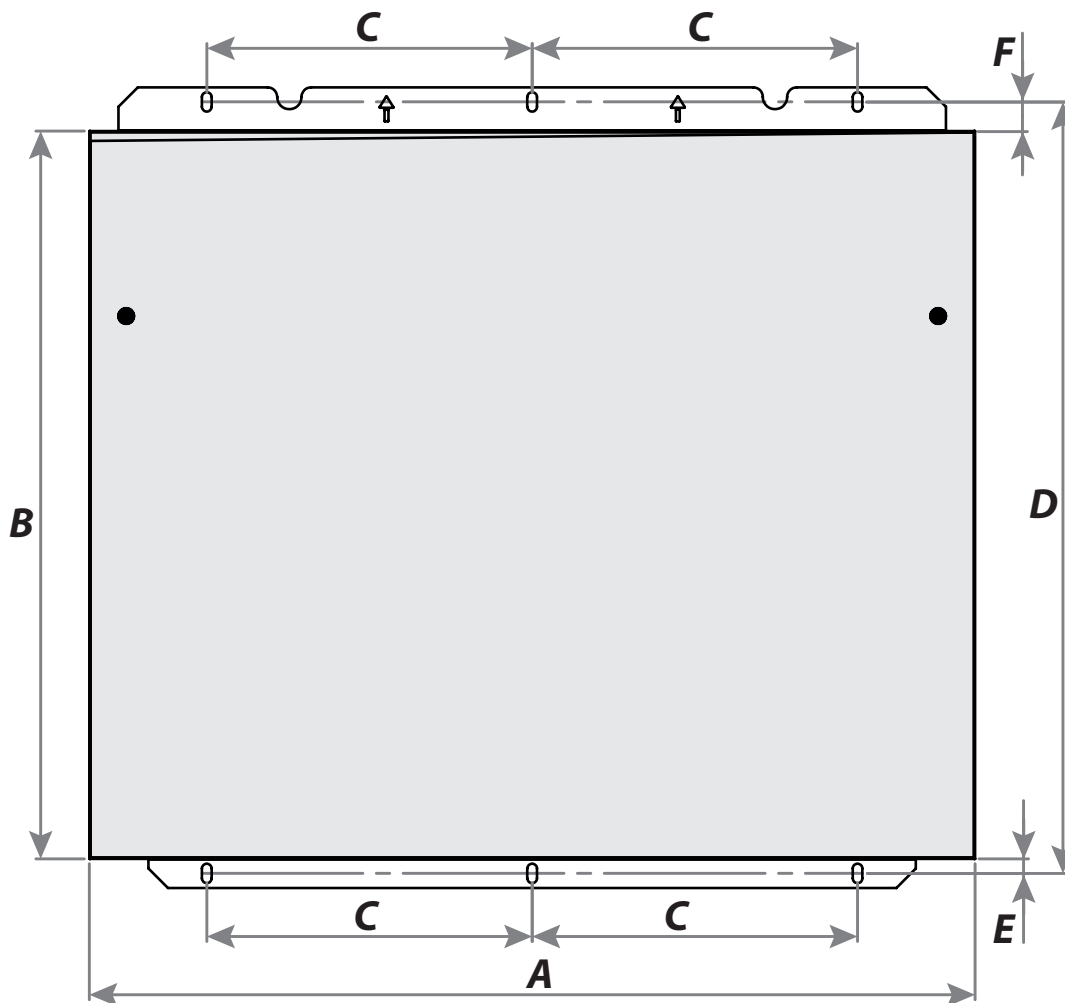

Installez la crédence au mur, comme montrer dans l'image ci-dessous, en utilisant les mesures pour le modèle acheté. Voir le tableau ci-dessus.

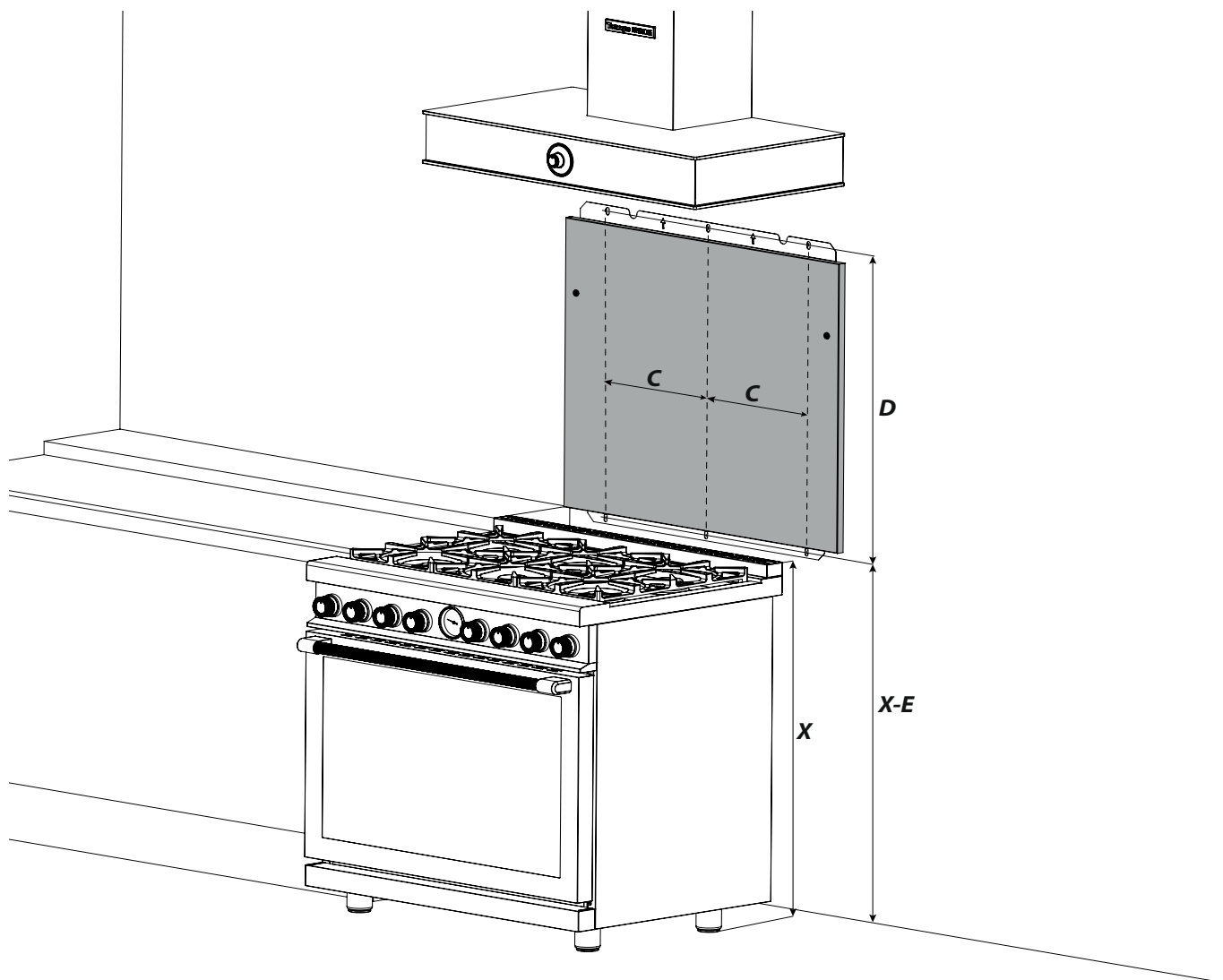

Lined writing area consisting of multiple horizontal lines for text entry.

WARRANTY

SUPERIORE WARRANTY

FULL TWO-YEAR WARRANTY

For two years from the date of the original purchase, SUPERIORE, will repair or replace (at its option) any part of the range which fails due to a defect in materials or workmanship. During this full two years warranty, SUPERIORE will provide, free of charge, all labor and in-home service to repair or replace the defective part. This warranty is extended to the original purchaser and any succeeding owner with proper documentation of ownership for products purchased for residential use within the United States of America.

EXCLUSIONS

This warranty does not cover any defect or damage, which is not direct fault of SUPERIORE; this includes, but is not limited to:

- 1) Service trips to your home to instruct you how to use the product.
- 2) Service trips to your home, during which no fault is found.
- 3) Damages occurred during transit, handling and/or installation of the product.
- 4) Damages occurred in case the product has not been installed, duly following the manufacturer's installation instructions, as well as any local code or regulation.
- 5) Damages due to failure in following the manufacturer's recommended care, cleaning and maintenance instructions; in particular, damages to the oven and/or the cooktop if they have not been cared and cleaned according to these instructions.
- 6) Any repair, modification, alteration, or adjustment provided by any person not authorized by SUPERIORE.
- 7) Failure of the product if it is abused, misused or used for other than the intended purpose or if used commercially/industrially.
- 8) Incorrect electric current, voltage or power supply.
- 9) Improper setting of any control.
- 10) Replacement of house fuses or resetting of circuit breakers.
- 11) Replacement of the light bulbs.
- 12) Wear and tear
- 13) Any substance, accumulating in any part or component of the product.
- 14) Damages to anything situated next to the product, including, but not limited to, ceiling, floor or cabinetry.
- 15) Damage to the product caused by accident, fire, floods or acts of God.
- 16) Expenses for travel and transportation to locations more than 30 miles from an authorized SUPERIORE retailer.
- 17) Products with original serial numbers that have been removed.

The remedies described above are the only ones which SUPERIORE will provide, either under this warranty or under any warranty arising by operation of law. SUPERIORE will not be responsible for any consequential or incidental damages arising from the breach of this warranty or any other warranty, whether express, implied or statutory.

Some states do not allow the exclusion or limitation of incidental or consequential damages. This warranty gives you specific legal rights, and you may also have other rights which vary from state to state. To know what your legal rights are, consult your local state consumer affairs office or your state's Attorney General.

Service Information

If service is required, call your dealer or authorized service agency.

The name of the authorized service agency can be obtained from the dealer or distributor in your area, on calling 1-844-322-2111.

Have the following information readily available .

- Model number
- Serial number
- Date purchased
- Name of dealer from whom purchased
- Clearly describe the problem that you are having.

Record the information indicated below.

You will need it if service is ever required.

The model and serial number can be found by looking in the last page of this booklet.

A duplicate label is located inside of the range.

Model no. _____ Serial no. _____

Date of purchase _____ Date installed _____

Dealer's name _____

Address _____

If service requires installation of parts, use only authorized parts to insure protection under warranty.

Keep this manual for future reference.

